



 **TRONIK**

## Technical Specification





## General Description

The T-LOCK security system is a solution designed for refrigerated semi-trailers, but also compatible with vehicles equipped with 14V installation. It's not just a simple semi-trailer door lock, but a well-thought-out mechanism for total security. Advanced features include 4 solid steel bolts on the sides of the door and a steel plate on the left door to prevent any attempted breakout.

T-LOCK is discreetly mounted on the inside of the semi-trailer door without taking up valuable cargo space. What's more, the system can be expanded to include light sensors, induction loops in the walls and ceiling, or an audible alarm to provide complete protection anywhere and anytime.



## Features and options

Way of connecting GPS	RS 485
Voltage Supply	12 - 30 V
Minimum current capacity	5A
Working temperature scope	- 30°C +65°C
Dimensions of T-Lock	390 mm x 145 mm x 15 mm
Possibility to connect an additional battery	Yes
Max. T-Lock force	2500 N (push/pull)
IP protection class	IP65 / IP69K
Remote opening	Yes
Emergency opening	Yes
One-time codes	Yes
Alerting in case of unauthorized opening	Yes
T-Lock security visible from outside	No
Number of up/down bolts	2
Number of side bolts on the door	4
Diameter of bolts	25mm
Thickness of the left door locking plate	3mm
Ability to connect additional sensors (motion sensor, light sensor, door opening sensor, induction loops, etc.)	Yes

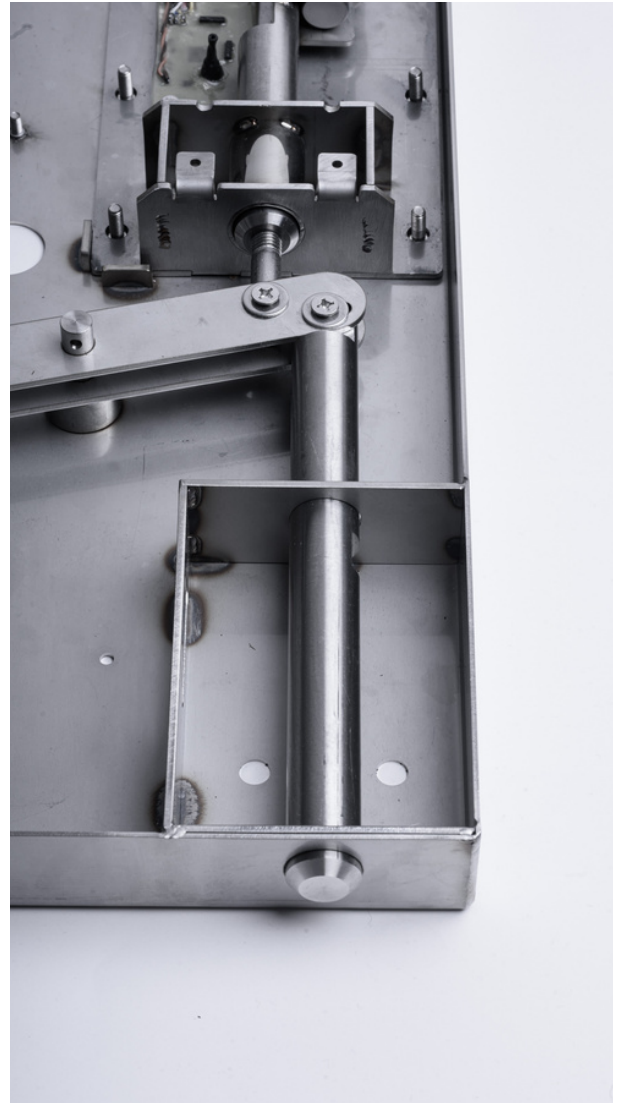

# Technical Drawing

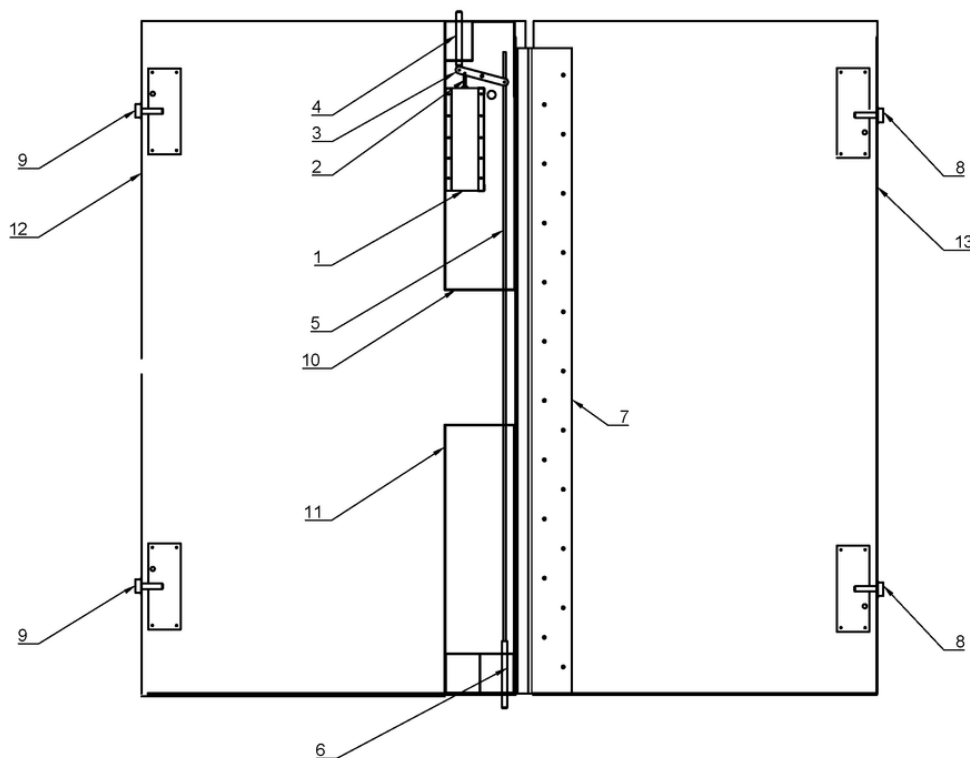

1. Electric linear motor housing
2. Locking pin lever plunger
3. Locking pin lever
4. Upper locking pin
5. Lower locking pin extension
6. Lower locking pin
7. Left door lock
8. Left door shock absorber
9. Right door shock absorber
10. Upper locking mechanism housing
11. Lower rhyme mechanism housing
12. Right door
13. Left door

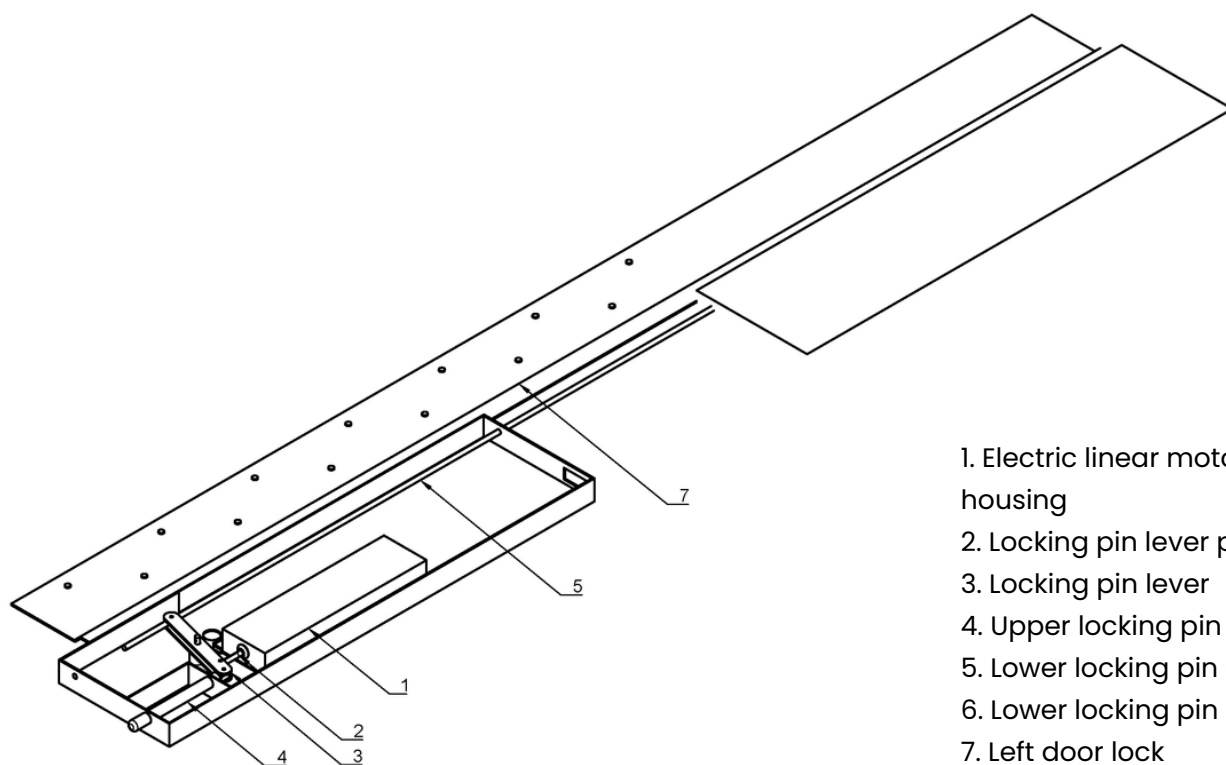

1. Electric linear motor housing
2. Locking pin lever plunger
3. Locking pin lever
4. Upper locking pin
5. Lower locking pin extension
6. Lower locking pin
7. Left door lock



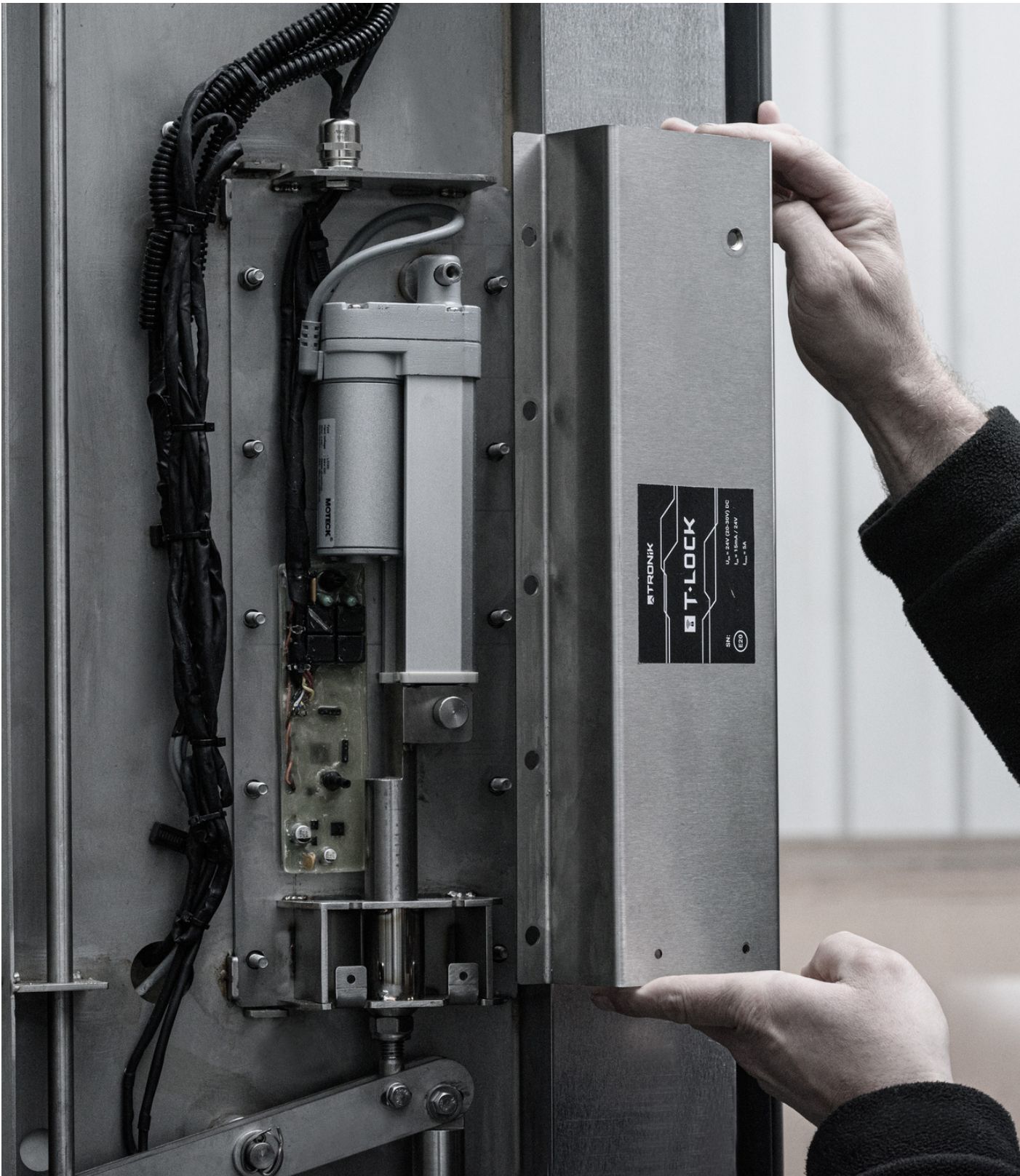

Watch the movie







# ABOUT **TRONIK**

With over two decades of unwavering dedication to excellence in the field of vehicle monitoring, Tronik stands as a proud industry leader in Poland, offering innovative solutions that provide comprehensive control over your vehicle fleet.

Our state-of-the-art vehicle monitoring system not only safeguards your vehicles but also generates tangible savings.

Discover why our company is one of the top players in the market and place your trust in us to gain full control over your fleet.

📍 [marketing@tronik.pl](mailto:marketing@tronik.pl)

☎️ +48 572 959 671

✉️ [biuro@tronik.pl](mailto:biuro@tronik.pl)

🌐 [www.tronik.pl](http://www.tronik.pl)



Producer of hardware and software:

**ATRAX<sub>4</sub>** | **T-LOCK** | **KT<sub>4</sub>**